

DATA SHEET

TDA3606A

**Multiple voltage regulator with
battery detection**

Product specification
File under Integrated Circuits, IC01

1997 Aug 12

Multiple voltage regulator with battery detection

TDA3606A

FEATURES

- One V_P -state controlled regulator
- Regulator and reset outputs operate during load dump
- Supply voltage range of -18 to $+50$ V
- Low quiescent current (battery detection switched off)
- High ripple rejection
- Dual reset output.

PROTECTIONS

- Reverse polarity safe (down to -18 V without high reverse current)
- Able to withstand voltages up to 18 V at the output (supply line may be short-circuited)
- ESD protected on all pins
- Load dump protection
- Foldback current limit protection for regulator
- DC short-circuit safe to ground and V_P of regulator output.

GENERAL DESCRIPTION

The TDA3606A is a low power voltage regulator. It contains:

1. One fixed voltage regulator with a foldback current protection, intended to supply a microprocessor, that also operates during load dump
2. A reset-signal can be used to interface with the microprocessor
3. Supply pin can withstand load dump pulses and negative supply voltages
4. Defined start-up behaviour; regulator will be switched on at a supply voltage higher than 7.6 V and off when the output voltage of the regulator drops below 2.4 V.

QUICK REFERENCE DATA

SYMBOL	PARAMETER	CONDITIONS	MIN.	TYP.	MAX.	UNIT
Supply						
V_P	supply voltage					
	operating	regulator on	5.6	14.4	25	V
	jump start	$t \leq 10$ minutes	–	–	30	V
	load dump protection	$t \leq 50$ ms; $t_r \geq 2.5$ ms	–	–	50	V
$I_{q(\text{tot})}$	total quiescent supply current	standby mode	–	95	120	μA
Voltage regulator						
V_{REG}	output voltage regulator	$7 \text{ V} \leq V_P \leq 18 \text{ V}$	4.85	5.0	5.15	V
		$0.5 \text{ mA} \leq I_{\text{REG}} \leq 150 \text{ mA}$	4.8	5.0	5.2	V
V_{REGd}	drop-out voltage	$I_{\text{REG}} = 150 \text{ mA}$	–	–	0.5	V

ORDERING INFORMATION

TYPE NUMBER	PACKAGE		
	NAME	DESCRIPTION	VERSION
TDA3606AT	SO20	plastic small outline package; 20 leads; body width 7.5 mm	SOT163-1

Multiple voltage regulator with battery detection

TDA3606A

BLOCK DIAGRAM

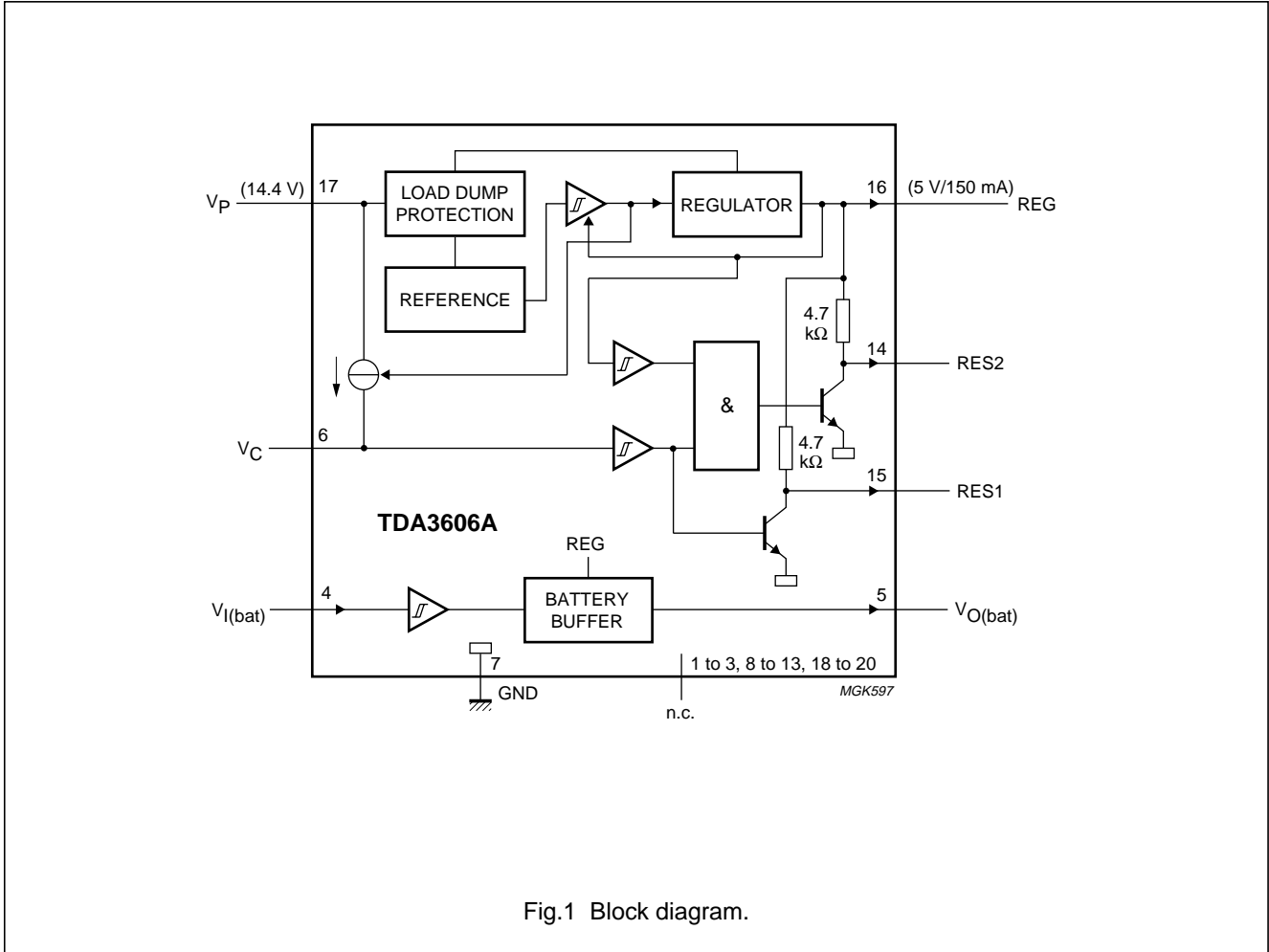

Fig.1 Block diagram.

Multiple voltage regulator with battery detection

TDA3606A

PINNING

SYMBOL	PIN	DESCRIPTION
n.c.	1 to 3	not connected; heat spreader
$V_{I(bat)}$	4	battery input voltage
$V_{O(bat)}$	5	battery detection output voltage
V_C	6	reset delay capacitor
GND	7	ground (0 V)
n.c.	8 to 13	not connected; heat spreader
RES2	14	reset 2 output
RES1	15	reset 1 output
REG	16	regulator output
V_P	17	supply voltage
n.c.	18 to 20	not connected; heat spreader

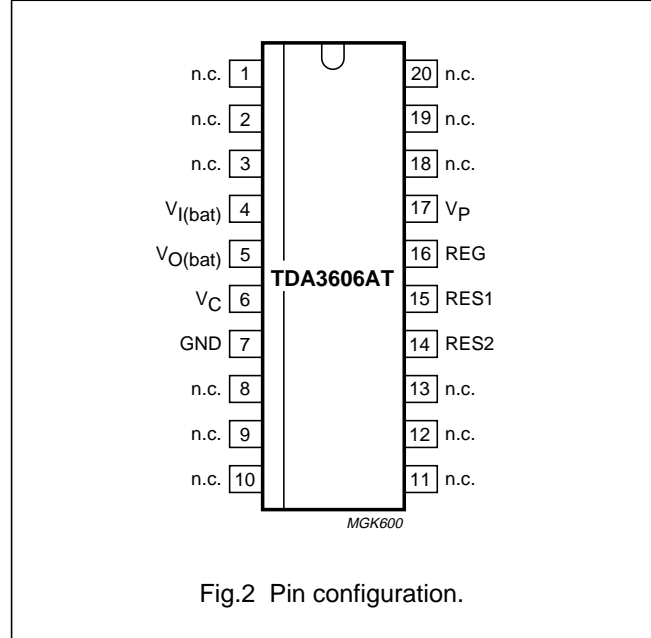

FUNCTIONAL DESCRIPTION

The TDA3606A is a voltage regulator intended to supply a microprocessor (e.g. in car radio applications). Because of low voltage operation of the application, a low-voltage drop regulator is used in the TDA3606A.

This regulator will switch on when the supply voltage exceeds 7.6 V for the first time and will switch off again when the output voltage of the regulator drops below 2.4 V. When the regulator is switched on, the RES1 and RES2 outputs (RES2 can only be HIGH when RES1 is HIGH) will go HIGH after a fixed delay time (fixed by an external delay capacitor) to generate a reset to the microprocessor.

RES1 will go HIGH by an internal pull-up resistor of 4.7 kΩ, and is used to initialize the microprocessor. RES2 is used to indicate that the regulator output voltage is within its voltage range. This start-up feature is built-in to secure a smooth start-up of the microprocessor at first connection, without uncontrolled switching of the regulator during the start-up sequence.

All output pins are fully protected. The regulator is protected against load dump and short-circuit (foldback current protection).

Interfacing with the microprocessor can be accomplished by means of a battery Schmitt-trigger and output buffer (simple full/semi on/off logic applications). The battery output will go HIGH when the battery input voltage exceeds the HIGH threshold level.

Multiple voltage regulator with battery detection

TDA3606A

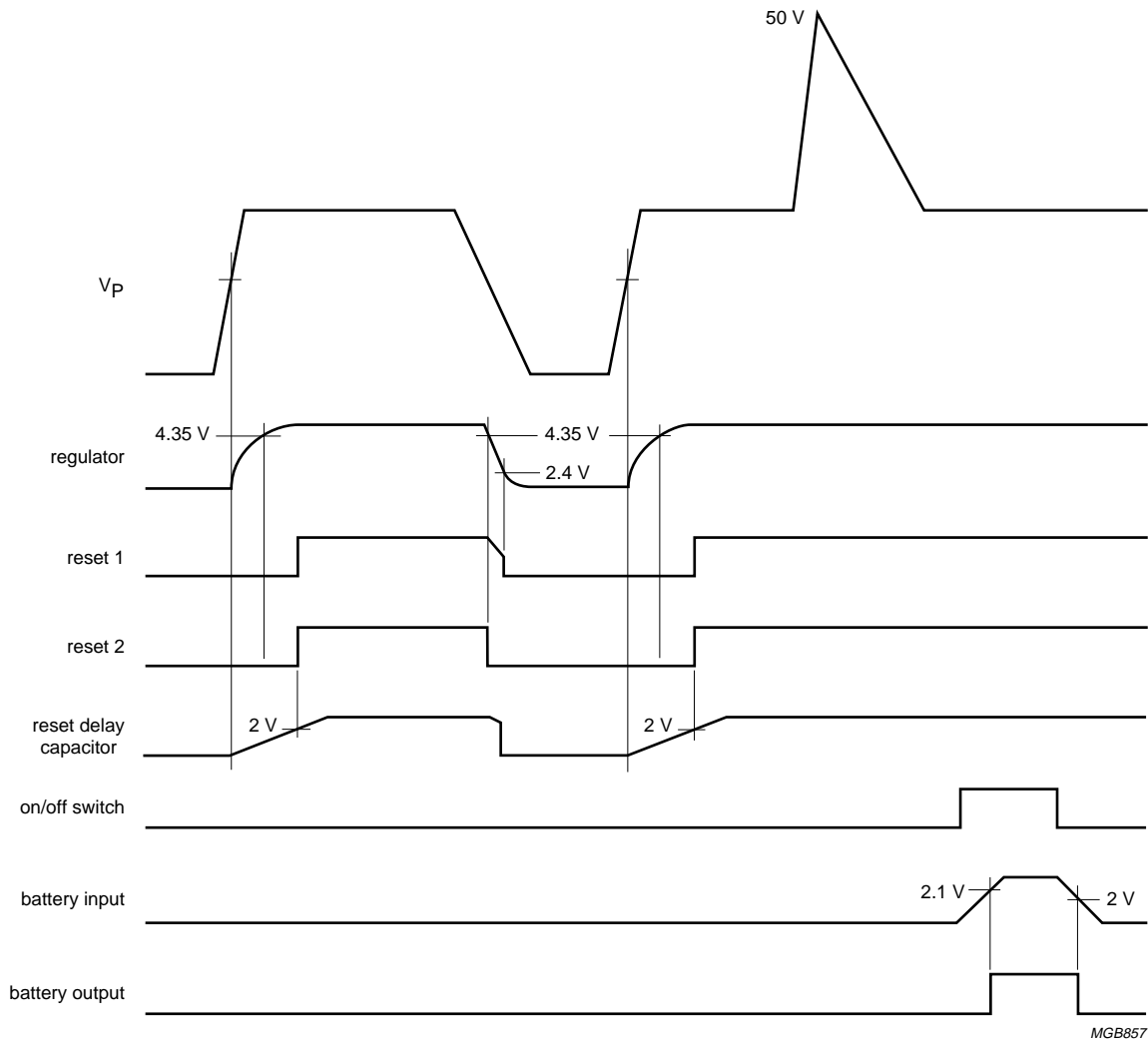

Fig.3 Timing diagrams.

Multiple voltage regulator with battery detection

TDA3606A

LIMITING VALUES

In accordance with the Absolute Maximum Rating System (IEC 134).

SYMBOL	PARAMETER	CONDITIONS	MIN.	MAX.	UNIT
V_P	supply voltage	regulator on	–	25	V
	operating	$t \leq 10$ minutes	–	30	V
	jump start	$t \leq 50$ ms; $t_r \geq 2.5$ ms	–	50	V
V_P	reverse battery voltage	non-operating	–	–18	V
$V_{I(bat)p}$	positive pulse voltage at battery input	$V_P = 14.4$ V; $R_I = 5$ k Ω	–	50	V
$V_{I(bat)n}$	negative pulse voltage at battery input	$V_P = 14.4$ V; $R_I = 5$ k Ω	–	–100	V
P_{tot}	total power dissipation	$T_{amb} = 25$ °C	–	2.5	W
T_{stg}	storage temperature	non-operating	–55	+150	°C
T_{amb}	ambient temperature	operating	–40	+85	°C
T_j	junction temperature	operating	–40	+150	°C

THERMAL CHARACTERISTICS

SYMBOL	PARAMETER	CONDITIONS	VALUE	UNIT
$R_{th(j-p)}$	thermal resistance from junction to pins		20	K/W
$R_{th(j-a)}$	thermal resistance from junction to ambient	in free air; note 1	50	K/W
		in free air; note 2	60	K/W

Notes

1. On IMS board.
2. On standard board with double sided copper area connected to pins.

QUALITY SPECIFICATION

In accordance with "SNW-FQ-611E". The number of the quality specification can be found in the "Quality Reference Handbook". The handbook can be ordered using the code 9397 750 00192.

Multiple voltage regulator with battery detection

TDA3606A

CHARACTERISTICS

$V_P = 14.4\text{ V}$; $T_{\text{amb}} = 25\text{ °C}$; see Fig.5; unless otherwise specified.

SYMBOL	PARAMETER	CONDITIONS	MIN.	TYP.	MAX.	UNIT
Supply voltage						
V_P	supply voltage					
	operating	regulator on; note 1	5.6	14.4	25	V
	jump start	$t \leq 10$ minutes	–	–	30	V
	load dump protection	$t \leq 50$ ms, $t_r \geq 2.5$ ms	–	–	50	V
I_q	quiescent current	$V_P = 12.4\text{ V}$; note 2	–	95	120	μA
		$V_P = 14.4\text{ V}$; note 2	–	100	–	μA
		load dump; $V_P = 50\text{ V}$	–	5	20	mA
Schmitt-trigger for regulator and reset 1						
V_{thr}	rising supply voltage threshold		6.2	7.5	8.2	V
V_{thf}	falling voltage of regulator threshold	$I_{\text{REG}} = 5\text{ mA}$	2.1	2.4	2.7	V
		$I_{\text{REG}} = 30\text{ mA}$	–	2.25	–	V
V_{hys}	hysteresis		–	5.1	–	V
Schmitt-trigger for battery detection						
V_{thr}	rising voltage threshold		1.9	2.05	2.2	V
V_{thf}	falling voltage threshold		1.8	1.95	2.1	V
V_{hys}	hysteresis		–	0.1	–	V
Schmitt-trigger for reset 2						
V_{thr}	rising voltage of regulator	note 3	4.25	4.45	4.65	V
V_{thf}	falling voltage of regulator	note 3	4.15	4.35	4.55	V
V_{hys}	hysteresis		–	0.1	–	V
Reset 1 and reset 2 buffers						
I_{sink}	LOW-level sink current	$V_{\text{RES}} \leq 0.8\text{ V}$; note 3	2	–	–	mA
R_{pu}	internal pull-up resistor		3.7	4.7	5.7	k Ω
Reset delay						
I_o	output current		–	0.75	–	μA
V_{thr}	rising voltage threshold		1.4	2.0	2.8	V
t_d	delay time	$C_d = 47\text{ nF}$; note 4	40	125	–	ms
Battery buffer						
V_{OL}	LOW-level output voltage	$I_l = 0\text{ mA}$	0	0.05	0.8	V
V_{OH}	HIGH-level output voltage	$I_o = 5\text{ }\mu\text{A}$; note 5	–	5.0	5.2	V
I_{OL}	LOW-level output current	$V_{\text{OL}} \leq 0.8\text{ V}$	0.2	0.5	–	mA
I_{OH}	HIGH-level output current	$V_{\text{OH}} \geq 3\text{ V}$	0.3	1.0	–	mA

Multiple voltage regulator with battery detection

TDA3606A

SYMBOL	PARAMETER	CONDITIONS	MIN.	TYP.	MAX.	UNIT
Regulator (I_{REG} = 5 mA)						
V _O	output voltage	0.5 mA ≤ I _{REG} ≤ 150 mA; 7 V ≤ V _P ≤ 18 V	4.8	5.0	5.2	V
		18 V ≤ V _P ≤ 50 V; load dump; I _{REG} = 30 mA	4.75	5.0	5.25	V
I _o	output current	load dump; V _P > 25 V	–	–	100	mA
ΔV _{REG}	line regulation	7 V ≤ V _P ≤ 18 V	–	3	50	mV
ΔV _{REGL}	load regulation	0.5 mA ≤ I _{REG} ≤ 150 mA	–	–	70	mV
SVRR	supply voltage ripple rejection	f _i = 200 Hz; V _{i(p-p)} = 2 V; I _o = 5 mA	55	60	–	dB
V _{REGd}	drop-out voltage	I _{REG} = 150 mA; V _P = 5.5 V; note 6	–	0.9	1	V
I _{clr}	current limit	V _{REG} > 4.5 V; note 7	0.2	0.27	0.6	A
I _{scr}	short-circuit current	R _L ≤ 0.5 Ω; note 8	50	80	–	mA

Notes

1. Minimum operating voltage, only if V_P has exceeded 7.6 V.
2. The quiescent current is measured in standby mode. So, the battery input is connected to a low voltage source and R_L = ∞.
3. The voltage of regulator sinks as a result of a supply voltage drop.
4. The delay time can be calculated with the following formula: $t_d = \int \frac{C_d}{I_{ch}} dV_{thr} = \frac{C_d \times V_{thr}}{I_{ch}}$ (ms)
5. Battery output voltage will be equal or less than the output voltage of regulator.
6. The drop-out voltage of regulator is measured between V_P and V_{REG}.
7. At current limit, I_{clr} is held constant (behaviour according to dashed line in Fig.4).
8. The foldback current protection limits the dissipated power at short-circuit (see Fig.4).

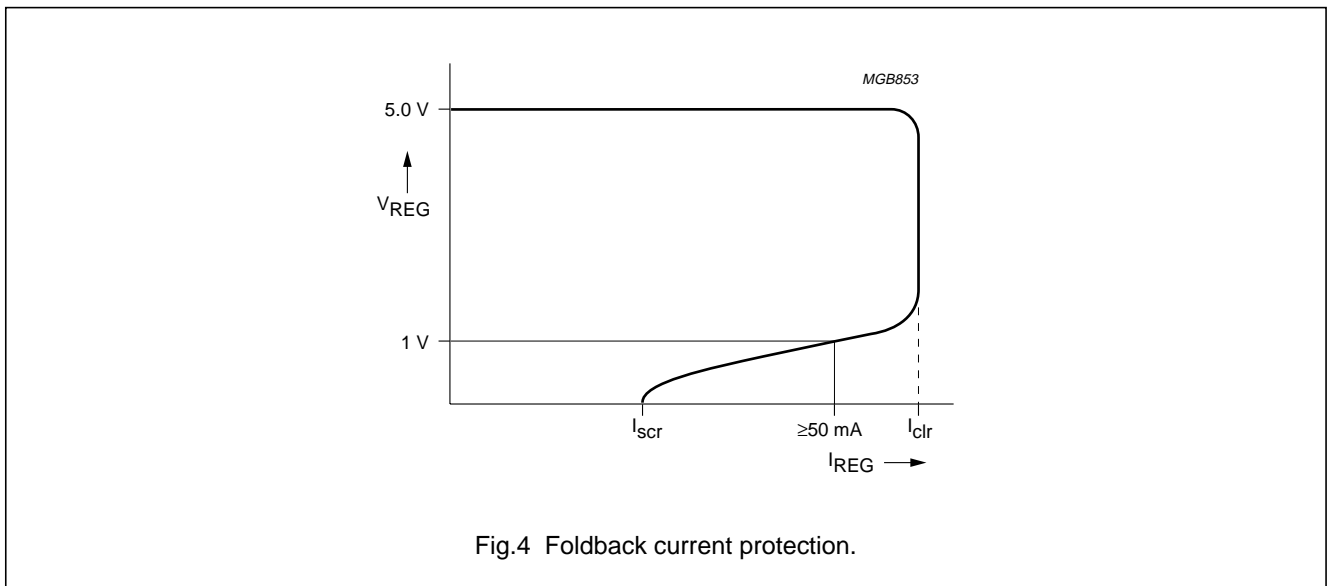

Fig.4 Foldback current protection.

Multiple voltage regulator with battery detection

TDA3606A

TEST AND APPLICATION INFORMATION

Test information

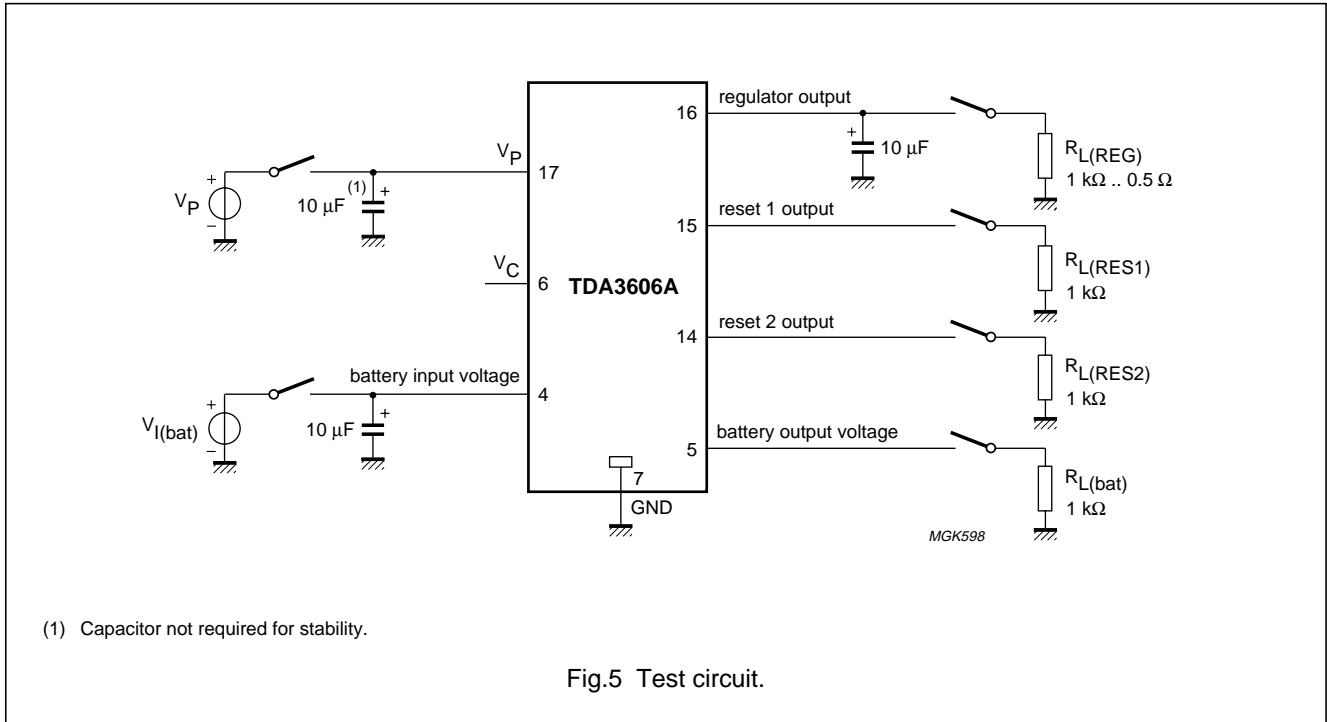

Application information

NOISE

The noise at the output of the regulator depends on the bandwidth of the regulator, which can be adjusted by means of the output capacitor. In Table 1 the noise figures are given.

Table 1 Noise figures

OUTPUT CURRENT I_o (mA)	NOISE FIGURE (μV) ⁽¹⁾		
	AT OUTPUT CAPACITOR C_L (μF)		
	10	47	100
0.5	58	50	45
50	250	200	180

Note

1. Measured at a bandwidth of 10 Hz to 100 kHz.

The noise on the supply line depends on the value of the supply capacitor and is caused by a current noise (output noise of the regulator is translated into a current noise by means of the output capacitor). When a high frequency capacitor of 220 nF in parallel with an electrolytic capacitor

of 100 μF is connected directly to pins 17 and 7 (supply and ground) the noise is minimized.

STABILITY

The regulator is stabilized by means of the output capacitor. The value of the output capacitor can be selected using the diagram shown in Fig.6. The following two examples show the effects of the stabilization circuit using different values for the output capacitor.

Example 1

The regulator is stabilized using an electrolytic output capacitor of 68 μF (ESR = 0.5 Ω). At $-40^\circ C$ the capacitor value is decreased to 22 μF and the ESR is increased to 3.5 Ω . The regulator will remain stable at a temperature of $-40^\circ C$.

Example 2

The regulator is stabilized using an electrolytic output capacitor of 10 μF (ESR = 3.3 Ω). At $-40^\circ C$ the capacitor value is decreased to 3 μF and the ESR is increased to 23.1 Ω . The regulator will be instable at a temperature of $-40^\circ C$. This can be solved using a tantalum capacitor of 10 μF .

Multiple voltage regulator with battery detection

TDA3606A

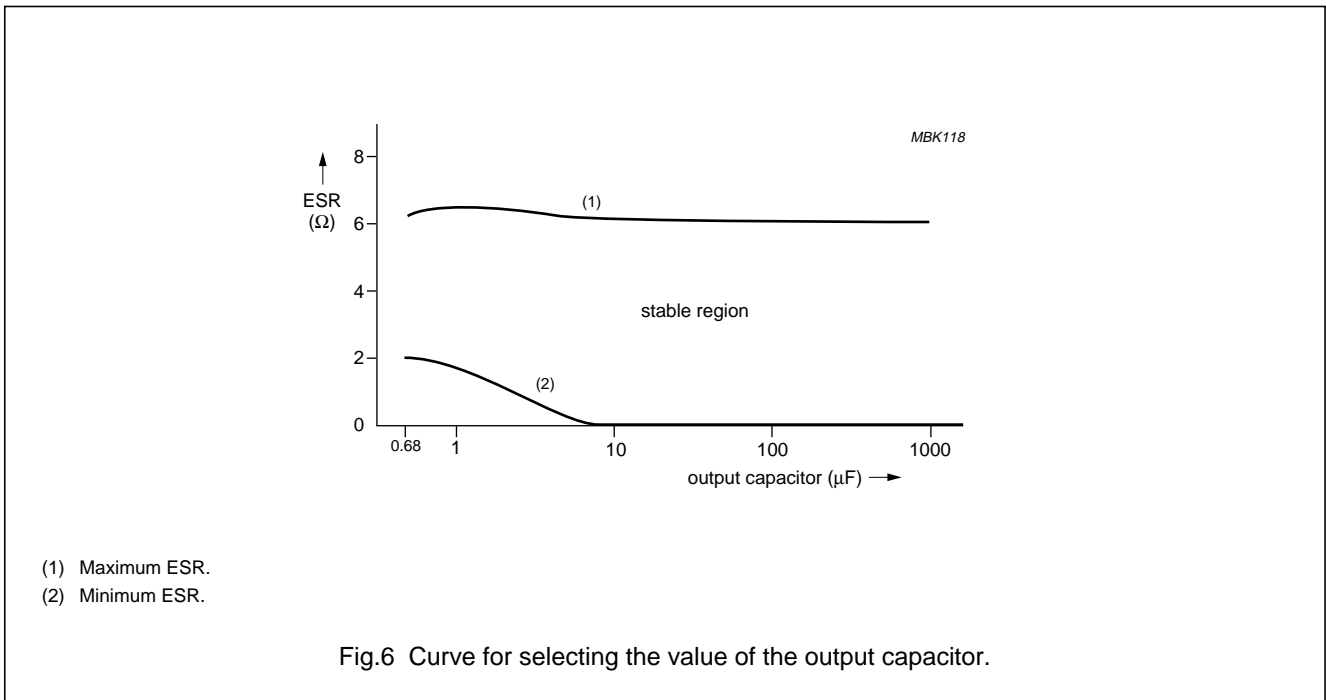

APPLICATION CIRCUITS

In Fig.7 the quiescent current equals $I_q + I_{R_{divider}}$. The specified quiescent current equals I_q . When the supply voltage is connected, the regulator will switch on when the supply voltage exceeds 7.6 V. With the aid of a timing capacitor at pin 6 the reset can be delayed (the timer starts at the same moment as the regulator is switched on).

Forced reset can be accomplished by short-circuiting the timer capacitor by using the push button switch. When the

push button is released again, the timer restarts (only when the regulator is on) causing a second reset on both RES1 and RES2.

The maximum output current of the regulator equals:

$$I_{max} = \frac{150 - T_{amb}}{R_{th\ j-a} \times (V_P - V_{REG})} = \frac{150 - T_{amb}}{50 \times (V_P - 5)} \text{ (mA)}$$

When $T_{amb} = 85 \text{ }^\circ\text{C}$, the maximum output current equals 138 mA. At lower ambient ($T_{amb} < 0$) temperature the maximum output current equals 320 mA.

Multiple voltage regulator with battery detection

TDA3606A

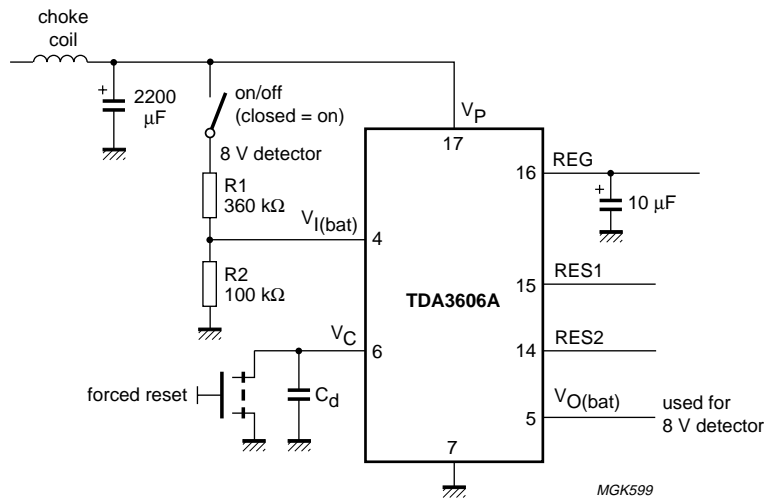

Fig.7 Typical application.

Multiple voltage regulator with battery detection

TDA3606A

PACKAGE OUTLINE

SO20: plastic small outline package; 20 leads; body width 7.5 mm

SOT163-1

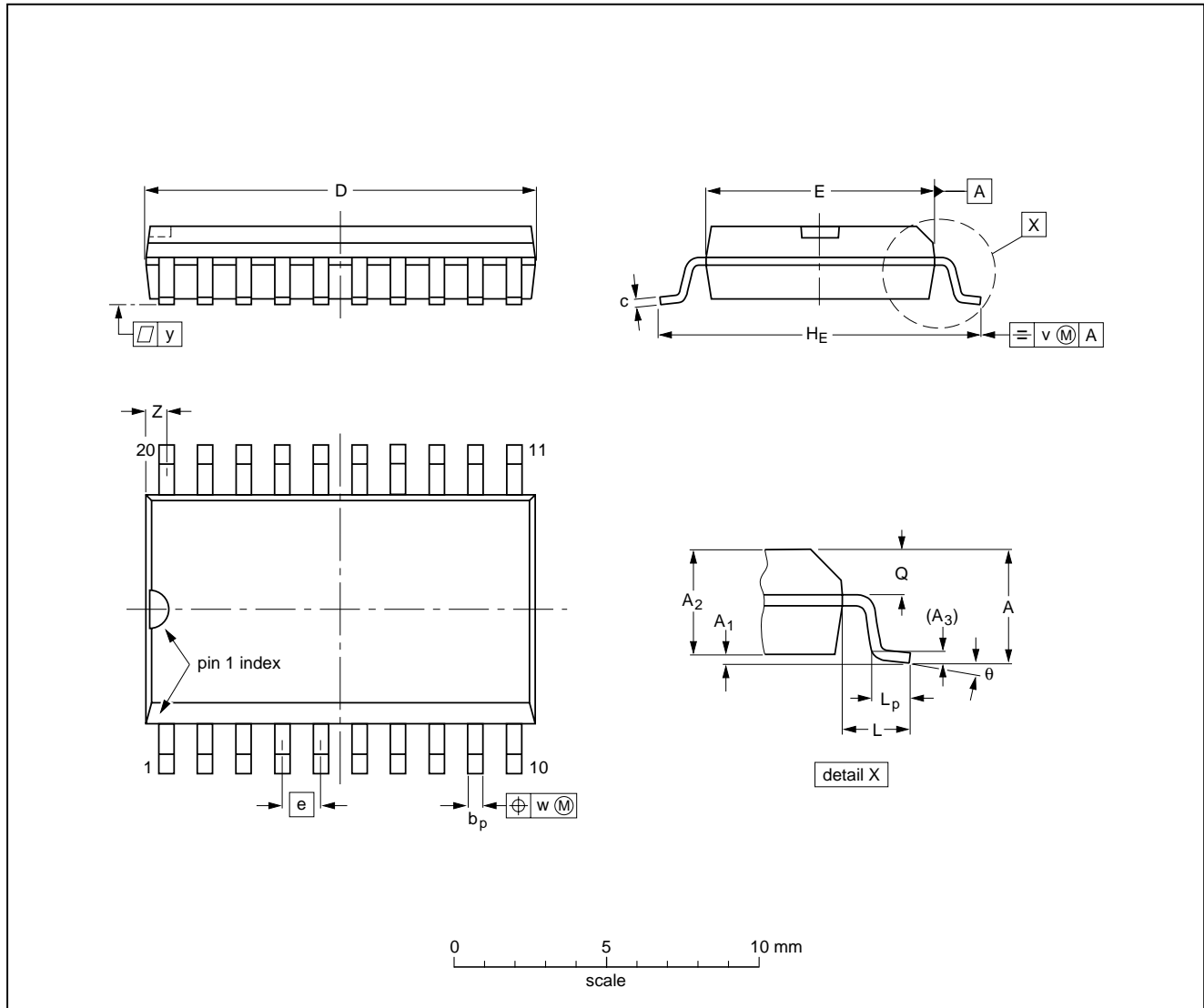

DIMENSIONS (inch dimensions are derived from the original mm dimensions)

UNIT	A max.	A ₁	A ₂	A ₃	b _p	c	D ⁽¹⁾	E ⁽¹⁾	e	H _E	L	L _p	Q	v	w	y	z ⁽¹⁾	θ
mm	2.65	0.30 0.10	2.45 2.25	0.25	0.49 0.36	0.32 0.23	13.0 12.6	7.6 7.4	1.27	10.65 10.00	1.4	1.1 0.4	1.1 1.0	0.25	0.25	0.1	0.9 0.4	8° 0°
inches	0.10	0.012 0.004	0.096 0.089	0.01	0.019 0.014	0.013 0.009	0.51 0.49	0.30 0.29	0.050	0.419 0.394	0.055	0.043 0.016	0.043 0.039	0.01	0.01	0.004	0.035 0.016	

Note

1. Plastic or metal protrusions of 0.15 mm maximum per side are not included.

OUTLINE VERSION	REFERENCES			EUROPEAN PROJECTION	ISSUE DATE
	IEC	JEDEC	EIAJ		
SOT163-1	075E04	MS-013AC			95-01-24 97-05-22

Multiple voltage regulator with battery detection

TDA3606A

SOLDERING

Introduction

There is no soldering method that is ideal for all IC packages. Wave soldering is often preferred when through-hole and surface mounted components are mixed on one printed-circuit board. However, wave soldering is not always suitable for surface mounted ICs, or for printed-circuits with high population densities. In these situations reflow soldering is often used.

This text gives a very brief insight to a complex technology. A more in-depth account of soldering ICs can be found in our "*IC Package Databook*" (order code 9398 652 90011).

Reflow soldering

Reflow soldering techniques are suitable for all SO packages.

Reflow soldering requires solder paste (a suspension of fine solder particles, flux and binding agent) to be applied to the printed-circuit board by screen printing, stencilling or pressure-syringe dispensing before package placement.

Several techniques exist for reflowing; for example, thermal conduction by heated belt. Dwell times vary between 50 and 300 seconds depending on heating method. Typical reflow temperatures range from 215 to 250 °C.

Preheating is necessary to dry the paste and evaporate the binding agent. Preheating duration: 45 minutes at 45 °C.

Wave soldering

Wave soldering techniques can be used for all SO packages if the following conditions are observed:

- A double-wave (a turbulent wave with high upward pressure followed by a smooth laminar wave) soldering technique should be used.
- The longitudinal axis of the package footprint must be parallel to the solder flow.
- The package footprint must incorporate solder thieves at the downstream end.

During placement and before soldering, the package must be fixed with a droplet of adhesive. The adhesive can be applied by screen printing, pin transfer or syringe dispensing. The package can be soldered after the adhesive is cured.

Maximum permissible solder temperature is 260 °C, and maximum duration of package immersion in solder is 10 seconds, if cooled to less than 150 °C within 6 seconds. Typical dwell time is 4 seconds at 250 °C.

A mildly-activated flux will eliminate the need for removal of corrosive residues in most applications.

Repairing soldered joints

Fix the component by first soldering two diagonally-opposite end leads. Use only a low voltage soldering iron (less than 24 V) applied to the flat part of the lead. Contact time must be limited to 10 seconds at up to 300 °C. When using a dedicated tool, all other leads can be soldered in one operation within 2 to 5 seconds between 270 and 320 °C.

**Multiple voltage regulator with battery
detection**

TDA3606A

DEFINITIONS

Data sheet status	
Objective specification	This data sheet contains target or goal specifications for product development.
Preliminary specification	This data sheet contains preliminary data; supplementary data may be published later.
Product specification	This data sheet contains final product specifications.
Limiting values	
Limiting values given are in accordance with the Absolute Maximum Rating System (IEC 134). Stress above one or more of the limiting values may cause permanent damage to the device. These are stress ratings only and operation of the device at these or at any other conditions above those given in the Characteristics sections of the specification is not implied. Exposure to limiting values for extended periods may affect device reliability.	
Application information	
Where application information is given, it is advisory and does not form part of the specification.	

LIFE SUPPORT APPLICATIONS

These products are not designed for use in life support appliances, devices, or systems where malfunction of these products can reasonably be expected to result in personal injury. Philips customers using or selling these products for use in such applications do so at their own risk and agree to fully indemnify Philips for any damages resulting from such improper use or sale.

Multiple voltage regulator with battery
detection

TDA3606A

NOTES

Philips Semiconductors – a worldwide company

Argentina: see South America

Australia: 34 Waterloo Road, NORTH RYDE, NSW 2113,
Tel. +61 2 9805 4455, Fax. +61 2 9805 4466

Austria: Computerstr. 6, A-1101 WIEN, P.O. Box 213, Tel. +43 160 1010,
Fax. +43 160 101 1210

Belarus: Hotel Minsk Business Center, Bld. 3, r. 1211, Volodarski Str. 6,
220050 MINSK, Tel. +375 172 200 733, Fax. +375 172 200 773

Belgium: see The Netherlands

Brazil: see South America

Bulgaria: Philips Bulgaria Ltd., Energoproject, 15th floor,
51 James Bourchier Blvd., 1407 SOFIA,
Tel. +359 2 689 211, Fax. +359 2 689 102

Canada: PHILIPS SEMICONDUCTORS/COMPONENTS,
Tel. +1 800 234 7381

China/Hong Kong: 501 Hong Kong Industrial Technology Centre,
72 Tat Chee Avenue, Kowloon Tong, HONG KONG,
Tel. +852 2319 7888, Fax. +852 2319 7700

Colombia: see South America

Czech Republic: see Austria

Denmark: Prags Boulevard 80, PB 1919, DK-2300 COPENHAGEN S,
Tel. +45 32 88 2636, Fax. +45 31 57 0044

Finland: Sinikalliontie 3, FIN-02630 ESPOO,
Tel. +358 9 615800, Fax. +358 9 61580920

France: 4 Rue du Port-aux-Vins, BP317, 92156 SURESNES Cedex,
Tel. +33 1 40 99 6161, Fax. +33 1 40 99 6427

Germany: Hammerbrookstraße 69, D-20097 HAMBURG,
Tel. +49 40 23 53 60, Fax. +49 40 23 536 300

Greece: No. 15, 25th March Street, GR 17778 TAVROS/ATHENS,
Tel. +30 1 4894 339/239, Fax. +30 1 4814 240

Hungary: see Austria

India: Philips INDIA Ltd, Band Box Building, 2nd floor,
254-D, Dr. Annie Besant Road, Worli, MUMBAI 400 025,
Tel. +91 22 493 8541, Fax. +91 22 493 0966

Indonesia: see Singapore

Ireland: Newstead, Clonskeagh, DUBLIN 14,
Tel. +353 1 7640 000, Fax. +353 1 7640 200

Israel: RAPAC Electronics, 7 Kehilat Saloniki St, PO Box 18053,
TEL AVIV 61180, Tel. +972 3 645 0444, Fax. +972 3 649 1007

Italy: PHILIPS SEMICONDUCTORS, Piazza IV Novembre 3,
20124 MILANO, Tel. +39 2 6752 2531, Fax. +39 2 6752 2557

Japan: Philips Bldg 13-37, Kohnan 2-chome, Minato-ku, TOKYO 108,
Tel. +81 3 3740 5130, Fax. +81 3 3740 5077

Korea: Philips House, 260-199 Itaewon-dong, Yongsan-ku, SEOUL,
Tel. +82 2 709 1412, Fax. +82 2 709 1415

Malaysia: No. 76 Jalan Universiti, 46200 PETALING JAYA, SELANGOR,
Tel. +60 3 750 5214, Fax. +60 3 757 4880

Mexico: 5900 Gateway East, Suite 200, EL PASO, TEXAS 79905,
Tel. +9-5 800 234 7381

Middle East: see Italy

Netherlands: Postbus 90050, 5600 PB EINDHOVEN, Bldg. VB,
Tel. +31 40 27 82785, Fax. +31 40 27 88399

New Zealand: 2 Wagener Place, C.P.O. Box 1041, AUCKLAND,
Tel. +64 9 849 4160, Fax. +64 9 849 7811

Norway: Box 1, Manglerud 0612, OSLO,
Tel. +47 22 74 8000, Fax. +47 22 74 8341

Philippines: Philips Semiconductors Philippines Inc.,
106 Valero St. Salcedo Village, P.O. Box 2108 MCC, MAKATI,
Metro MANILA, Tel. +63 2 816 6380, Fax. +63 2 817 3474

Poland: Ul. Lukiska 10, PL 04-123 WARSZAWA,
Tel. +48 22 612 2831, Fax. +48 22 612 2327

Portugal: see Spain

Romania: see Italy

Russia: Philips Russia, Ul. Usatcheva 35A, 119048 MOSCOW,
Tel. +7 095 755 6918, Fax. +7 095 755 6919

Singapore: Lorong 1, Toa Payoh, SINGAPORE 1231,
Tel. +65 350 2538, Fax. +65 251 6500

Slovakia: see Austria

Slovenia: see Italy

South Africa: S.A. PHILIPS Pty Ltd., 195-215 Main Road Martindale,
2092 JOHANNESBURG, P.O. Box 7430 Johannesburg 2000,
Tel. +27 11 470 5911, Fax. +27 11 470 5494

South America: Rua do Rocio 220, 5th floor, Suite 51,
04552-903 São Paulo, SÃO PAULO - SP, Brazil,
Tel. +55 11 821 2333, Fax. +55 11 829 1849

Spain: Balmes 22, 08007 BARCELONA,
Tel. +34 3 301 6312, Fax. +34 3 301 4107

Sweden: Kottbygatan 7, Akalla, S-16485 STOCKHOLM,
Tel. +46 8 632 2000, Fax. +46 8 632 2745

Switzerland: Allmendstrasse 140, CH-8027 ZÜRICH,
Tel. +41 1 488 2686, Fax. +41 1 481 7730

Taiwan: Philips Semiconductors, 6F, No. 96, Chien Kuo N. Rd., Sec. 1,
TAIPEI, Taiwan Tel. +886 2 2134 2865, Fax. +886 2 2134 2874

Thailand: PHILIPS ELECTRONICS (THAILAND) Ltd.,
209/2 Sanpavuth-Bangna Road Prakanong, BANGKOK 10260,
Tel. +66 2 745 4090, Fax. +66 2 398 0793

Turkey: Talatpasa Cad. No. 5, 80640 GÜLTEPE/ISTANBUL,
Tel. +90 212 279 2770, Fax. +90 212 282 6707

Ukraine: PHILIPS UKRAINE, 4 Patrice Lumumba str., Building B, Floor 7,
252042 KIEV, Tel. +380 44 264 2776, Fax. +380 44 268 0461

United Kingdom: Philips Semiconductors Ltd., 276 Bath Road, Hayes,
MIDDLESEX UB3 5BX, Tel. +44 181 730 5000, Fax. +44 181 754 8421

United States: 811 East Arques Avenue, SUNNYVALE, CA 94088-3409,
Tel. +1 800 234 7381

Uruguay: see South America

Vietnam: see Singapore

Yugoslavia: PHILIPS, Trg N. Pasica 5/v, 11000 BEOGRAD,
Tel. +381 11 625 344, Fax. +381 11 635 777

For all other countries apply to: Philips Semiconductors, Marketing & Sales Communications,
Building BE-p, P.O. Box 218, 5600 MD EINDHOVEN, The Netherlands, Fax. +31 40 27 24825

Internet: <http://www.semiconductors.philips.com>

© Philips Electronics N.V. 1997

SCA55

All rights are reserved. Reproduction in whole or in part is prohibited without the prior written consent of the copyright owner.

The information presented in this document does not form part of any quotation or contract, is believed to be accurate and reliable and may be changed without notice. No liability will be accepted by the publisher for any consequence of its use. Publication thereof does not convey nor imply any license under patent- or other industrial or intellectual property rights.

Printed in The Netherlands

547027/1200/01/pp16

Date of release: 1997 Aug 12

Document order number: 9397 750 02239

Let's make things better.

**Philips
Semiconductors**



PHILIPS